

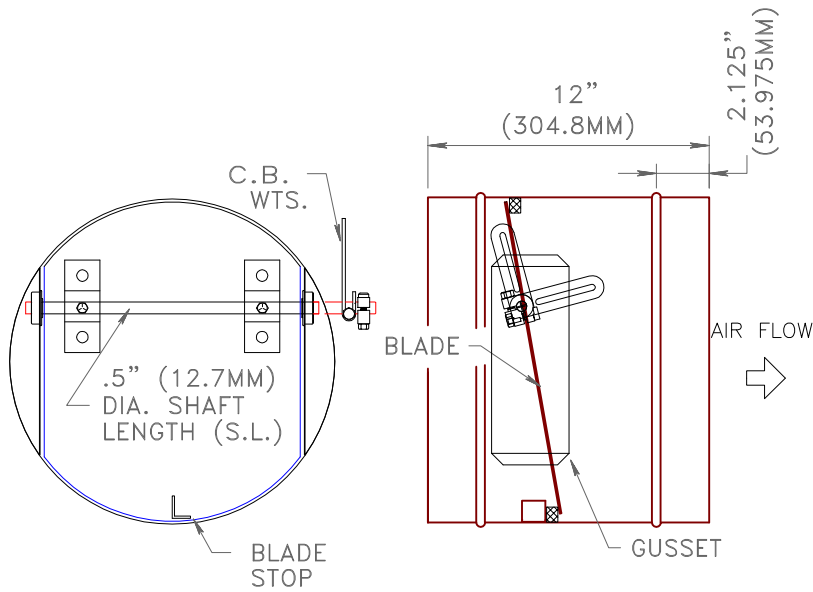

ROUND BACK DRAFT DAMPER BDS-R



STANDARD SPECIFICATION

- CONST. - ROLLED GALV. STEEL, 12" LONG ROUND PIPE, SPOT WELDED JOINT, (SEE CHART)
- BLADES - GALV. STEEL, (SEE CHART)
- STOPS - 1" X 1" (25.4MM X 25.4MM) X 16 GA. GALV. ANGLE
- SEALS - .25" X .38" (6.4MM X 9.7MM) POLYESTER FOAM
- SHAFTS - .5" (12.7MM) DIA. C.R. PLATED STEEL
- BEARINGS - .5" (12.7MM) DIA. BALL BEARINGS
- C.B. WTS. - OUT OF AIRSTREAM FOR EASY ADJUSTMENT
- FINISH - MILL GALV. STEEL
- SIZES - 6" TO 24" (152.4MM X 609.6MM)

OPTIONS

- MATERIAL - STAINLESS STEEL, ALUMINUM

NOMINAL DIAMETER DIM.	PIPE GAUGE	BLADE GAUGE	GUSSET GAUGE	SHAFT DIA.	SHAFT LENGTH (S.L.)	SHIPPING WEIGHT (LBS.)
6"	24	24	24	.5"	8"	6
8"	24	24	24	.5"	10"	8
10"	24	24	24	.5"	12"	10
12"	24	24	24	.5"	14"	12
14"	22	22	22	.5"	16"	14
16"	22	22	22	.5"	18"	16
18"	22	22	22	.5"	20"	18
20"	20	20	20	.5"	22"	20
22"	20	20	20	.5"	24"	22
24"	20	20	20	.5"	26"	24

TECHNICAL NOTES

- MAX. REC. INTAKE VEL. - 2000 FPM THROUGH FREE AREA AT 4" S.P. W.G. MAX.
- C.B. WEIGHT - ADJUSTABLE TO NEAR 0 STATIC
- MAX. TEMPERATURE - 150° F

DAMPER IS MANUFACTURED .25" (6.35MM) SMALLER THAN NOMINAL PIPE SIZE

* FOR MORE INFORMATION, CONTACT OUR FACTORY *

NOTES	APPROVAL
DATE: PROJECT: ENGINEER: CUSTOMER: DISTRIBUTOR:	

BDS-R