

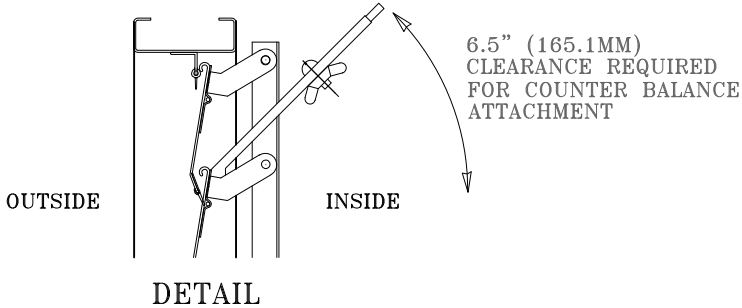

# BACKDRAFT DAMPER BDSS-3C3-LB



**STANDARD SPECIFICATIONS**

- CONST. - 16 GA. 304 STAINLESS STEEL, WELDED FRAME
- FRAME - 3" X 1" X .064", 16 GA. (76.2MM X 25.4MM X 1.6MM) FORMED STAINLESS STEEL CHANNEL
- BLADES - 3.5" (88.9MM) X 24 GAUGE STAINLESS STEEL BLADE, 3.06" (77.7MM) BLADE SPACING
- SEALS - DUAL DUROMETER VINYL BLADE SEAL, -40° F. TO +200° F.
- SHAFTS - .19" X 1.25" (4.8MM X 31.8MM) PLATED STEEL
- BEARINGS - .19" (4.8MM) NYLON BUSHINGS
- LINKAGE - INSIDE AIRSTREAM, ON ENTERING SIDE
- C.B. WTS. - AS PER OUR FACTORY GUIDELINES
- FINISH - MILL ALUMINUM
- SIZE - MINIMUM 12" W X 12" H (304.8MM X 304.8MM)
- MAXIMUM 32" W X 60" H (812.8MM X 1524MM)

**OPTIONS**

- FRAME - FLANGE, REVERSE FLANGE 3" X 1.5" 76.2MM X 38.1MM)
- SCREEN - AS REQUIRED, BDSS-3C3-LB, SCREEN IS ON FACE. WHEN SCREEN IS USED BLADES ONLY OPEN TO APPROX. 45°.
- FINISH - ANODIZED, PRIME COAT, BAKED ENAMEL

**TECHNICAL NOTES**

- CAUTION - DO NOT USE FOR INTAKE UNLESS WITH OUTSIDE WEATHER COWL
- BDSS-3C3-LB - RECOMMENDED ON LARGER DAMPERS BECAUSE OF LINKAGE WEIGHT
- MAX. RECOMMENDED VEL. - 3000 FPM
- MAXIMUM TEMPERATURE - 200° F.
- MAXIMUM WIDTH - 5.5" (139.7MM) WHEN BLADE IS IN FULL OPEN POSITION PLUS CLEARANCE FOR COUNTER BALANCE WEIGHTS SEE ABOVE
- SHIPPING WEIGHT - APPROX. 5 LB/SQ. FT.

DAMPERS 3F3 AND 3R3 ARE MANUFACTURED .5" (12.7MM) SMALLER THAN OPENING SIZE UNLESS EXACT DIMENSIONS ARE STATED. DAMPERS 3C3 ARE MANUFACTURED .25" (6.4MM) SMALLER THAN OPENING SIZE UNLESS EXACT DIMENSIONS ARE STATED.

\* FOR MORE INFORMATION, CONTACT OUR FACTORY \*

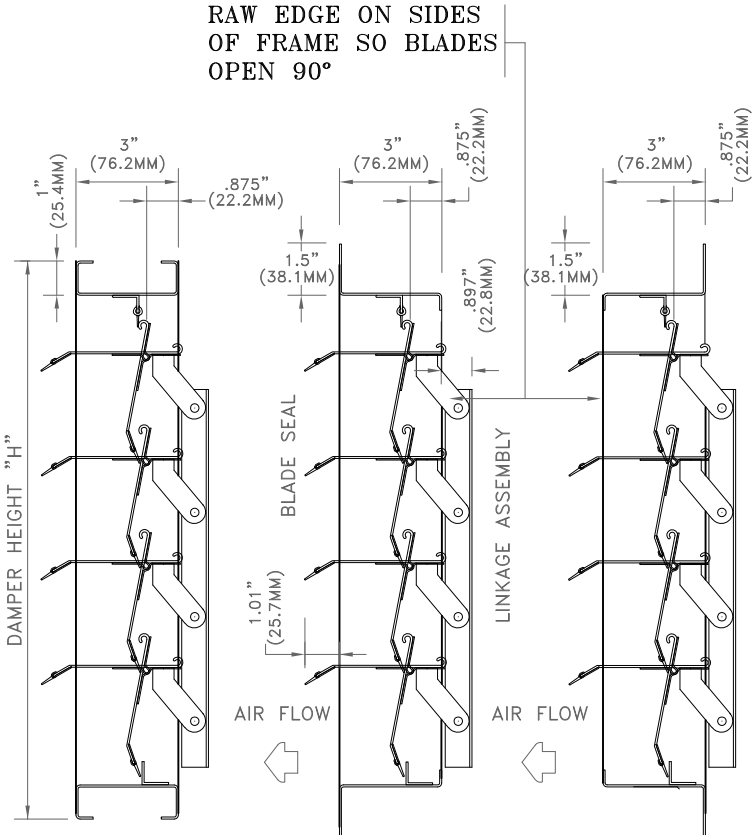

**BDSS-3C3-LB SECTION**  
STANDARD CHANNEL FRAME

**BDSS-3F3-LB SECTION**  
OPTIONAL FLANGED FRAME

**BDSS-3RF-LB SECTION**  
OPTIONAL REVERSE FLANGE FRAME

NOTE: PLEASE SPECIFY WHETHER YOU WANT - CHANNEL FLANGE, OR REVERSE FLANGE AND WALL MOUNT OR CEILING MOUNT.

NOTES	APPROVAL
DATE: PROJECT: ENGINEER: CUSTOMER: DISTRIBUTOR:	<div style="border: 1px solid black; width: 100%; height: 100%;"></div>

BDSS-3C3-LB