

westvent®

BACK DRAFT DAMPER BDSS-4C3-LB

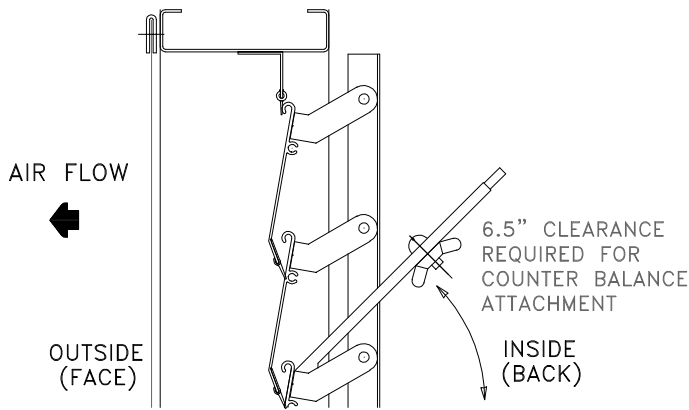

FIG "A"

STANDARD SPECIFICATIONS

- CONST. - 16 GA. 304 STAINLESS STEEL, WELDED FRAME
- FRAME - 4" X 1" X .064", 16 GA. (101.6MM X 25.4MM X 1.6MM) FORMED STAINLESS STEEL CHANNEL, BUTT CORNERS WELDED
- BLADES - 3.5" X .028", 24 GA. (88.9MM X .7MM) STAINLESS STEEL, 3.06" (77.7MM) BLADE SPACING
- SEALS - DUAL DUROMETER VINYL ON BLADE TIPS
- SHAFTS - 0.19" (4.8MM) DIA. STAINLESS STEEL PINS
- BEARINGS - 0.19" (4.8MM) NYLON BUSHINGS
- LINKAGE - STAINLES STEEL IN AIRSTREAM ON AIR ENTERING SIDE
- C.B. WTS.- STAINLESS STEEL AS REQUIRED 4 BLADES HIGH AND OVER
- FINISH - MILL STAINLESS STEEL
- SIZE - MINIMUM 12" X 12" (304.8MM X 304.8MM)
MAXIMUM 32" X 60" (812.8MM X 1524MM)

OPTIONS

- C.B. WTS.- ADJUSTABLE TO NEAR ZERO STATIC
- FRAME - ADD ON FLANGE FRAME
- SCREEN - .5" X .5" (12.7MM X 12.7MM) X 18 GA. GALV.

TECHNICAL NOTES

- CAUTION - DO NOT USE FOR INTAKE UNLESS WITH OUTSIDE WEATHER COWL.
- MAX. RECOMMENDED VEL. - 3000 FPM
 - MAX. TEMPERATURE - 200 DEG. F
 - SHIPPING WEIGHT - APPROX. 7 LB/SQ. FT.

DAMPER IS MANUFACTURED .25" (6.4MM) SMALLER THAN ORDERED SIZE UNLESS EXACT DIMENSIONS ARE STATED.

* FOR MORE INFORMATION, CONTACT OUR FACTORY *

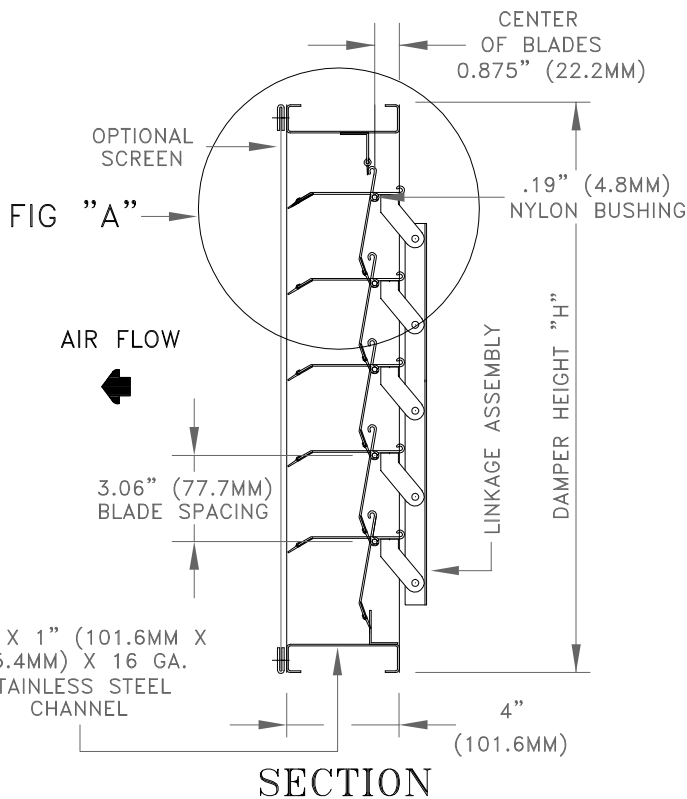

SECTION

NOTES

APPROVAL

DATE:
PROJECT:
ENGINEER:
CUSTOMER:
DISTRIBUTOR:

BDSS-4C3-LB