

westvent®

BACK DRAFT DAMPER BDX-4C3-LB

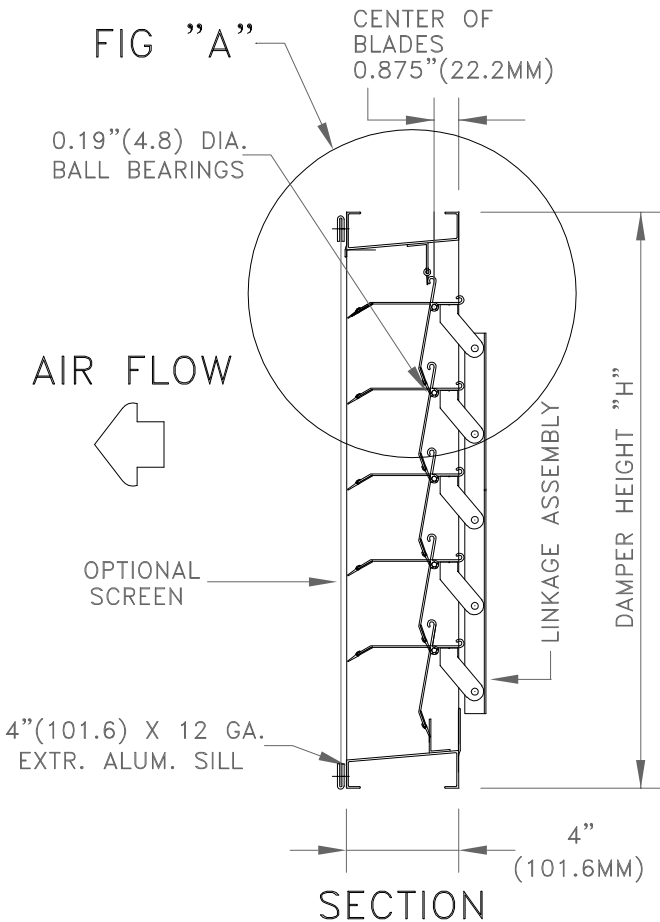
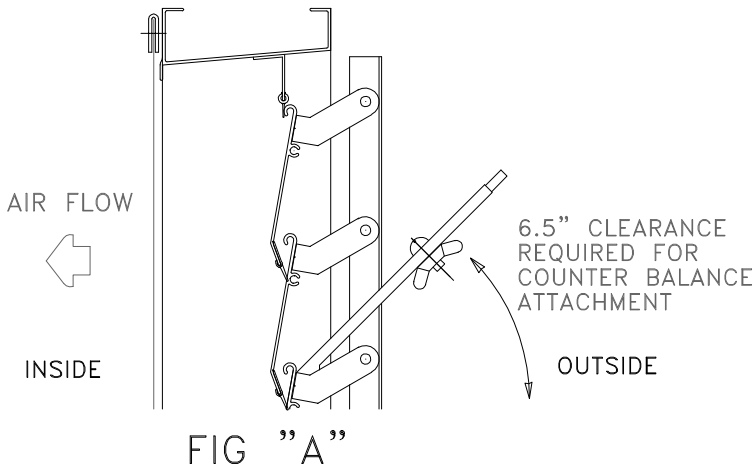

STANDARD SPECIFICATIONS

- CONST. - 12 GA. ALUMINUM FRAME AND EXTRUDED BLADES
- FRAME - 4" (101.6MM) X 12 GA. EXTRUDED ALUM. CHANNEL, BUTT CORNERS WELDED, 5° SLOPED HEAD & SILL
- BLADES - 3.5" (88.9MM) X 14 GA. TAPERED EXTR. ALUMINUM. 3.06" (77.7MM) BLADE SPACING
- SEALS - DUAL DUROMETER VINYL ON BLADE TIPS
- SHAFTS - 0.19" (4.8MM) DIA. C.R. PLATED STEEL PINS
- BEARING - 0.19" (4.8MM) BALL BEARINGS
- LINKAGE - IN AIRSTREAM ON AIR ENTERING SIDE
- C.B. WTS.- AS REQUIRED 4 BLADES HIGH & OVER
- FINISH - MILL ALUMINUM
- SIZE - MINIMUM 12" X 12" (304.8MM X 304.8MM)
MAXIMUM 32" X 60" (812.8MM X 1524MM)

OPTIONS

- C.B. WTS.- ADJUSTABLE TO NEAR ZERO STATIC
- FRAME - ADD ON FLANGE FRAME
- SCREEN - .5" X .5" (12.7MM X 12.7MM) X 18 GA. GALV.
.5" X .5" (12.7MM X 12.7MM) X 12 GA. ALUM.
- FINISH - ANODIZED, BAKED ENAMEL & PRIME COAT

TECHNICAL NOTES

- CAUTION - DO NOT USE FOR INTAKE UNLESS WITH OUTSIDE WEATHER COWL.
- MAX. RECOMMENDED VEL. - 3000 FPM
 - MAX. TEMPERATURE - 200 DEG. F
 - SHIPPING WEIGHT - APPROX. 5 LB/SQ.FT.

DAMPER IS MANUFACTURED .25" (6.4MM) SMALLER THAN ORDERED SIZE UNLESS EXACT DIMENSIONS ARE STATED.

* FOR MORE INFORMATION, CONTACT OUR FACTORY *

NOTES

APPROVAL

DATE:
PROJECT:
ENGINEER:
CUSTOMER:
DISTRIBUTOR:

BDX-4C3-LB