

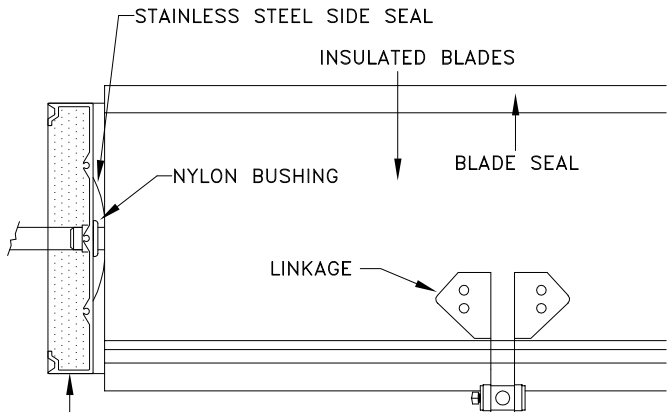

# COMMERCIAL ALUMINUM INSULATED DAMPER INX-6C6-LI



6" X 1" X .081"  
(152.4MM X 25.4MM X 2.1MM)  
EXTR. ALUM. INSULATED CHANNEL

**HORIZONTAL SECTION DETAIL**  
(2:1 FROM DRAWING BELOW)

**STANDARD SPECIFICATIONS**

- CONST. - 6063-T5 EXTRUDED ALUMINUM - INSULATED
- FRAME - 6" X 1" X .081", (152.4MM X 25.4MM X 2.1MM)  
WELDED BUTT CORNERS, MULLIONS AND SPREADER BARS ON ALL SECTIONS 48" (1219.2MM) AND LARGER.
- BLADES - 6" X 1.16" X .076 (152.4MM X 29.5MM X 1.9MM)  
EXTRUDED ALUMINUM BLADE C/W R6.5 FOAM INSUL.
- SEALS - DUAL DUROMETER VINYL BLADE SEAL, -40° F. TO +200F., 2.7" (68.6MM) S.S. SIDE SEALS
- SHAFTS - .5" (12.7MM) DIA. C.R. PLATED STEEL
- BEARINGS - .5" (12.7MM) NYLON BUSHINGS
- LINKAGE - INSIDE AIRSTREAM, ROD TRAVEL 5.25" (133.4MM)
- DRIVE - .5" (12.7MM) DIA. C.R. PLATED STEEL EXTENDING 6" SHAFT (152.4MM) OUT OF FRAME
- FINISH - MILL ALUMINUM
- SIZE - MINIMUM 10" W X 10" H (254MM X 254MM)  
- MAXIMUM 48" W X 72" H (1219.2MM X 1828.8MM)

**OPTIONS**

- BEARINGS - .5" (12.7MM) BALL BEARINGS
- SEALS - SANTOPRENE BULB: -50° F TO +250° F
- JACK
- SHAFTS - SEE SIZING CHARTS
- CONTROL - MANUAL, JACK SHAFTS, MOTORIZED, ETC.

**TECHNICAL NOTES**

- MAX. RECOMMENDED VEL. - 4000 FPM
- MAX. SYSTEM PRESSURE - SEE CHART
- LEAKAGE - LESS THAN 0.6% AT 10" W.G.
- SHIPPING WEIGHT - APPROX. 6 LB/SQ. FT.
- LARGER SIZES - MULTIPLE SECTIONS WILL BE PROVIDED FOR RE-ASSEMBLY BY OTHERS

DAMPER IS MANUFACTURED .25" (6.4MM) SMALLER THAN ORDERED SIZE UNLESS EXACT DIMENSIONS ARE STATED

\* FOR MORE INFORMATION, CONTACT OUR FACTORY \*

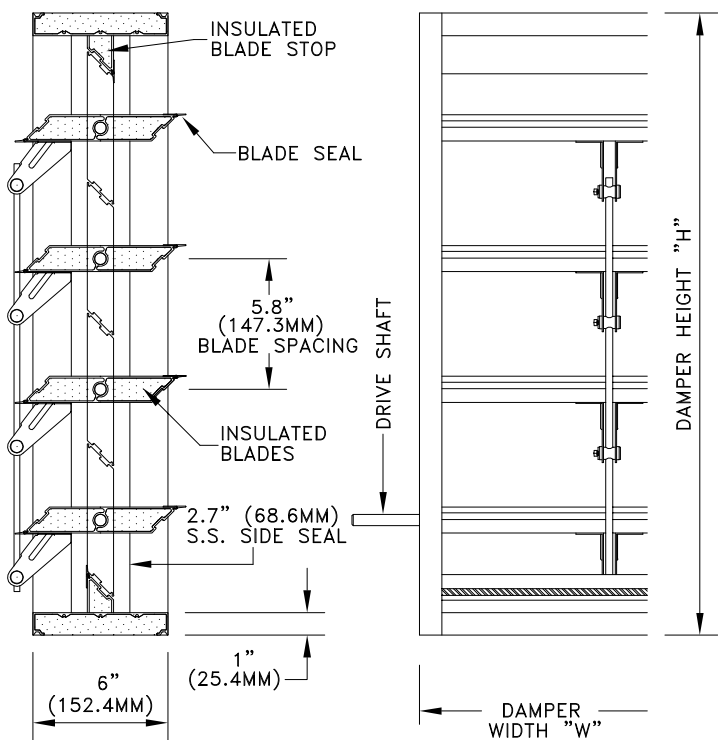

**SECTION**

**ELEVATION**

**NOTES**

**APPROVAL**

DATE:  
PROJECT:  
ENGINEER:  
CUSTOMER:  
DISTRIBUTOR:

IT-909-IXI



# ALUMINUM INSULATED DAMPER INX-6C6-LI

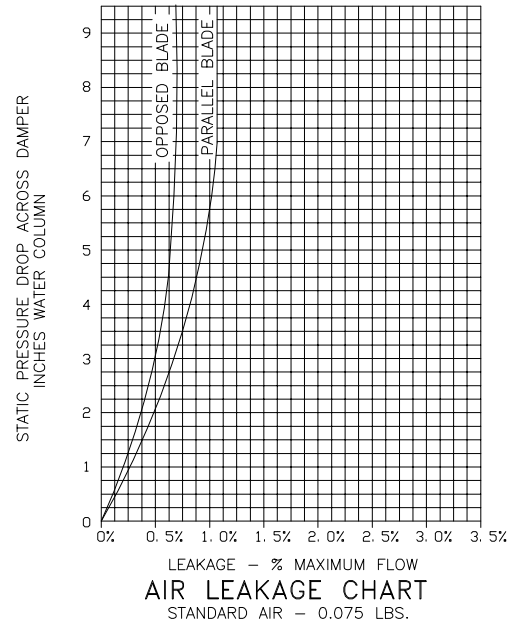
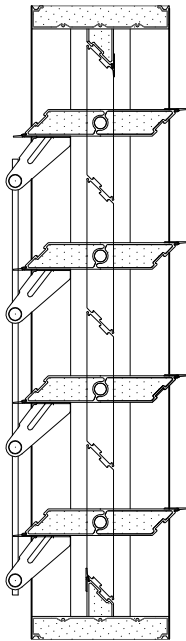

**TORQUE REQUIREMENT CHART: INCH - LBS./SQ. FT.**

1000 F.P.M. @ 2" W.G.	1000 - 2000 F.P.M. @ 3" W.G. (X 1.5)	2000 - 3000 F.P.M. @ 4" W.G. (X 2.0)
OPPOSED BLADE 5 IN. LBS./SQ. FT.	OPPOSED BLADE 7.5 IN. LBS./SQ. FT.	OPPOSED BLADE 10 IN. LBS./SQ. FT.
PARALLEL BLADE 7 IN. LBS./SQ. FT.	PARALLEL BLADE 10.5 IN. LBS./SQ. FT.	PARALLEL BLADE 14 IN. LBS./SQ. FT.

**MAXIMUM SYSTEM PRESSURE**

12" WIDE 10" SP W.G.	24" WIDE 9" SP W.G.	36" WIDE 8" SP W.G.	48" WIDE 6" SP W.G.
-------------------------	------------------------	------------------------	------------------------

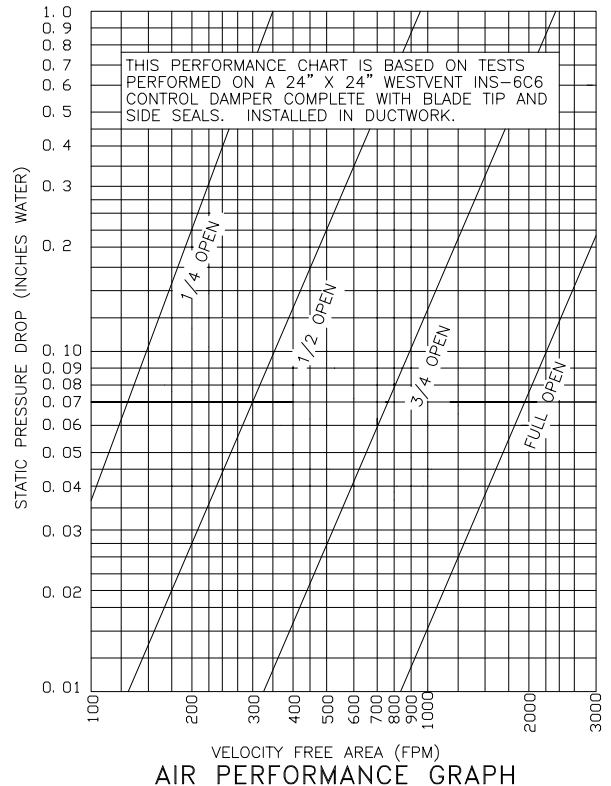
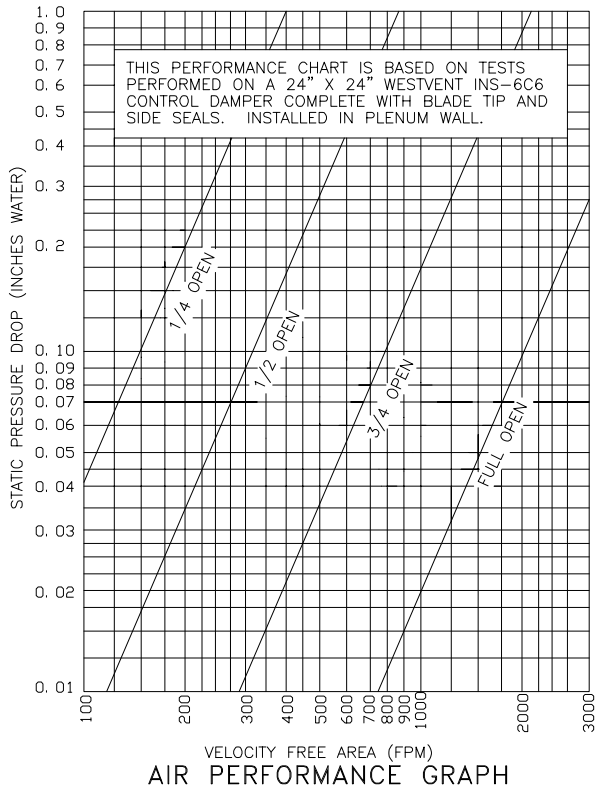

THE INFORMATION CONTAINED ON THIS DATA SHEET REMAINS THE PROPERTY OF WESTERN VENTILATION PRODUCTS LTD. AND IS PROTECTED BY COPYRIGHT. WESTVENT AIR PERFORMANCE RATINGS SHOWN ARE BASED ON TESTS MADE BY TECHNICIANS IN OUR TEST LABORATORY.