

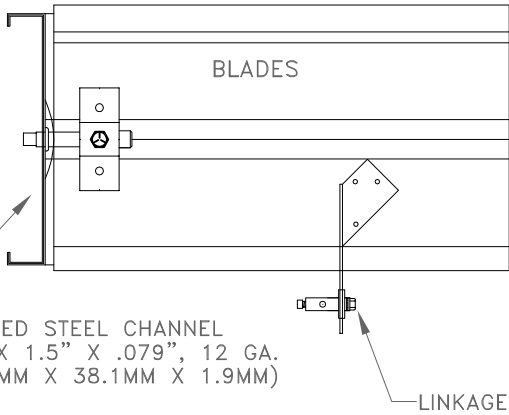

# INDUSTRIAL PARALLEL BLADE DAMPER PBS-10C10



FORMED STEEL CHANNEL  
10" X 1.5" X .079", 12 GA.  
(254MM X 38.1MM X 1.9MM)

LINKAGE

HORIZONTAL SECTION DETAIL

STANDARD SPECIFICATIONS

- CONST. - FORMED GALVANIZED STEEL. WELDS COATED WITH ZINC RICH PAINT
- FRAME - 10" X 1.5" X .079", 14 GA. (254MM X 38.1MM X 1.9MM) GALVANIZED STEEL CHANNEL
- BLADES - 10" X .064", 16 GA. (254MM X 1.6MM) GALVANIZED STEEL
- SEALS - DUAL DUROMETER VINYL BLADE SEAL, -40 DEG. F. TO +200 DEG. F., S.S. SIDE SEALS
- SHAFTS - .5" (12.7MM) DIA. C.R. PLATED STEEL
- BEARINGS - .5" (12.7MM) PRESSED IN BALL BEARINGS
- LINKAGE - IN AIRSTREAM
- DRIVE SHAFT - .5" (12.7MM) DIA. C.R. PLATED STEEL
- FINISH - MILL GALVANIZED STEEL
- SIZE - MINIMUM 12" W X 12" H (304.8MM X 304.8MM)  
- MAXIMUM 48" W X 96" H (1219.2MM X 2438.4MM)

OPTIONS

- BEARINGS - STAINLESS STEEL BUSHINGS, NYLON BUSHINGS, 2 BOLT FLANGE SELF ALIGNING
- JACK SHAFTS - SEE SIZING CHARTS
- CONTROL - MANUAL, JACK SHAFTS, MOTORIZED, ETC.

TECHNICAL NOTES

- CAUTION - AIRFOIL DAMPERS ADVISED WITHIN 5 DIA. OF FAN DISCHARGE
- MAX. RECOMMENDED VEL. - 2000 FPM
- MAXIMUM TEMPERATURE - 200 DEG. FAHRENHEIT
- SHIPPING WEIGHT - APPROX. 10 LB/SQ. FT.
- LARGER SIZES - MULTIPLE SECTIONS WILL BE PROVIDED FOR RE-ASSEMBLY BY OTHERS

*INDUSTRIAL DAMPERS ARE MANUFACTURED TO INSIDE DIMENSIONS UNLESS OTHERWISE STATED*

\* FOR MORE INFORMATION, CONTACT OUR FACTORY \*

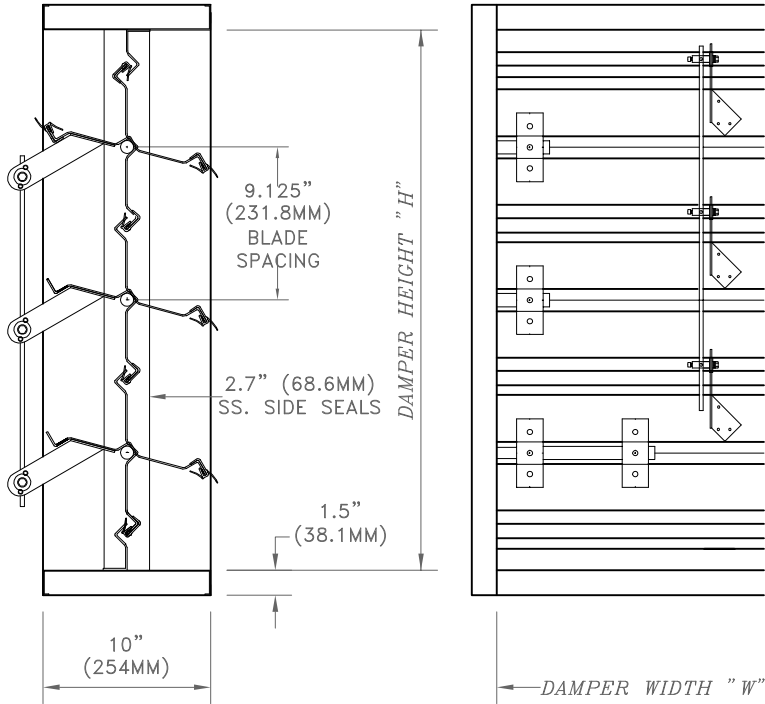

SECTION

ELEVATION (CLOSED  
BLADE POSITION SHOWN)

NOTES

APPROVAL

DATE:  
PROJECT:  
ENGINEER:  
CUSTOMER:  
DISTRIBUTOR:

PBS-10C10