

HORIZONTAL SECTION



STEEL LOUVER
SC-445 SF-445

STANDARD SPECIFICATIONS

- CONST. - FORMED GALVANIZED STEEL, WELDED ASSEMBLY
- FRAME - 4" X 1" X 16 GAUGE (101.6MM X 25.4MM X 1.6MM), CHANNEL UP TO 48" (1219.2MM), 4" X 1.5" X 16 GA. (101.6MM X 38.1MM X 1.6MM) OVER 48" (1219.2MM) BUTT CORNERS
- BLADES - 4" X 16 GA. (101.6MM X 1.6MM), SET AT 45°, 4.5" (114.3MM) SPACING
- SCREEN - .5" X .5" (12.7MM X 12.7MM) X 18 GA. GALVANIZED, SCREW FASTENED
- FINISH - MILL GALVANIZED, SEE TECHNICAL NOTES
- SIZE - MINIMUM 12" W X 12" H (304.8MM X 304.8MM)
 MAXIMUM SECTION WIDTH 72" (1828.8MM)
 MAXIMUM SECTION HEIGHT 120" (3048MM)
 MAXIMUM SECTION SIZE 40 SQ. FT.

OPTIONS

- CONST. - CONTINUOUS BLADE
- FRAME - SF - FLANGE FRAME 2" X 16 GA. (50.8MM X 1.6MM) STEEL ANGLE, MITERED CORNERS
- SCREEN - AS PER REQUEST
- FINISH - MINIMUM PRIME COAT OR BAKED ENAMEL IS RECOMMENDED

TECHNICAL NOTES

- CORROSION RESISTANCE IS LOST UPON WELDING, SEE OPTIONAL FINISHES ABOVE
- MAX. REC. INTAKE VEL. - 700 FPM THROUGH FREE AREA
- SHIPPING WEIGHT - APPROX. 8 LBS./SQ. FT.
- LOUVERS ARE MANUFACTURED .5" (12.7MM) SMALLER THAN ORDERED SIZE UNLESS EXACT DIMENSIONS ARE STATED

* FOR MORE INFORMATION, CONTACT OUR FACTORY *

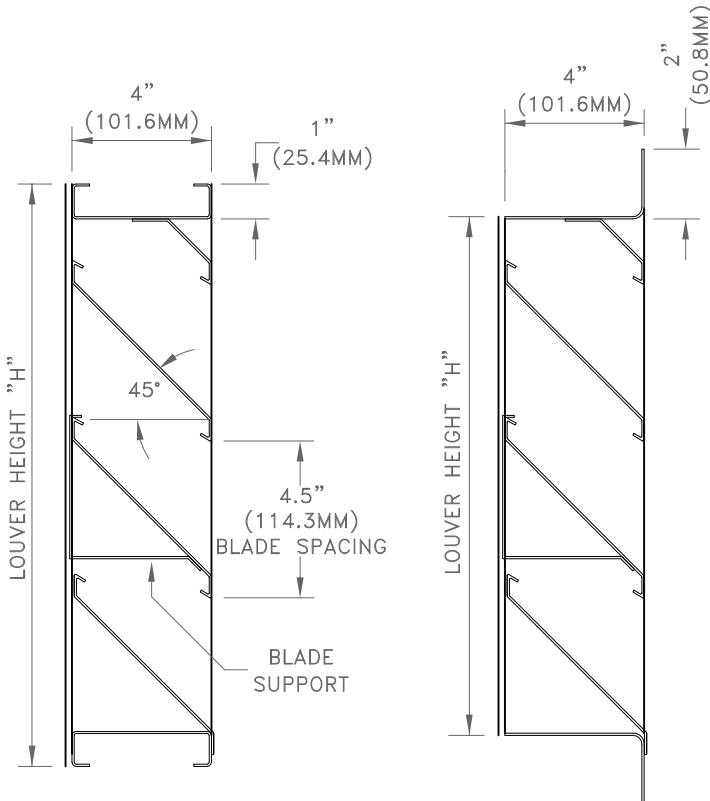

SC-445
VERTICAL SECTION

SF-445
VERTICAL SECTION

NOTES

APPROVAL

DATE:
PROJECT:
ENGINEER:
CUSTOMER:
DISTRIBUTOR:

SC-445



STEEL LOUVER SC-445

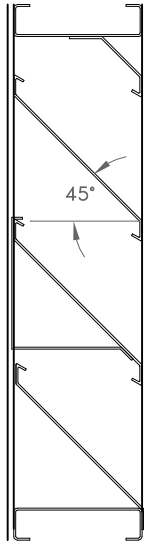

TEST
CONDITIONS:
A 48" X 48"
LOUVER WAS
USED FOR
THE TEST
AT STANDARD
AND
OPERATING
TEMPERATURE
RANGE OF
65°F - 85°F,
AND
15 MINUTES
TEST DURATION
WATER PENETRATION

	WIDTH (INCHES)											
	12	18	24	30	36	42	48	54	60	66	72	
12	0.20	0.32	0.44	0.57	0.69	0.81	0.93	1.06	1.18	1.30	1.43	
16	0.39	0.64	0.89	1.13	1.38	1.62	1.87	2.12	2.36	2.61	2.85	
20	0.58	0.94	1.31	1.67	2.03	2.39	2.76	3.12	3.48	3.84	4.21	
24	0.71	1.16	1.60	2.04	2.49	2.93	3.37	3.82	4.26	4.71	5.15	
28	0.84	1.37	1.89	2.42	2.94	3.47	3.99	4.52	5.04	5.57	6.09	
32	0.99	1.60	2.22	2.83	3.44	4.06	4.67	5.29	5.90	6.52	7.13	
36	1.18	1.92	2.66	3.40	4.13	4.87	5.61	6.35	7.08	7.82	8.56	
40	1.37	2.22	3.08	3.93	4.79	5.64	6.50	7.35	8.20	9.06	9.91	
44	1.50	2.44	3.37	4.31	5.24	6.18	7.11	8.05	8.98	9.92	10.86	
48	1.63	2.65	3.66	4.68	5.70	6.71	7.73	8.75	9.76	10.78	11.80	
52	1.77	2.88	3.99	5.09	6.20	7.31	8.41	9.52	10.62	11.73	12.84	
56	1.97	3.20	4.43	5.66	6.89	8.12	9.35	10.58	11.81	13.03	14.26	
60	2.16	3.50	4.85	6.20	7.54	8.89	10.23	11.58	12.93	14.27	15.62	
64	2.29	3.72	5.14	6.57	8.00	9.43	10.85	12.28	13.71	15.13	16.56	
68	2.42	3.93	5.44	6.94	8.45	9.96	11.47	12.98	14.49	16.00	17.50	
72	2.56	4.16	5.76	7.36	8.95	10.53	12.15	13.75	15.35	16.94	18.54	
76	2.76	4.48	6.20	7.92	9.64	11.36	13.09	14.81	16.53	18.25	19.97	
80	2.95	4.79	6.62	8.46	10.30	12.14	13.97	15.81	17.65	19.49	21.32	
84	3.08	5.00	6.92	8.83	10.75	12.67	14.59	16.51	18.43	20.35	22.27	
88	3.21	5.21	7.21	9.21	11.21	13.21	15.21	17.21	19.21	21.21	23.21	
92	3.35	5.44	7.53	9.62	11.71	13.80	15.89	17.98	20.07	22.16	24.25	
96	3.55	5.76	7.97	10.19	12.40	14.61	16.82	19.04	21.25	23.46	25.67	
100	3.74	6.07	8.39	10.72	13.05	15.38	17.71	20.04	22.37	24.70	27.03	
104	3.87	6.28	8.69	11.10	13.51	15.92	18.33	20.74	23.15	25.56	27.97	
108	4.00	6.49	8.98	11.47	13.96	16.46	18.95	21.44	23.93	26.42	28.91	
112	4.14	6.72	9.30	11.88	14.47	17.05	19.63	22.21	24.79	27.37	29.95	
116	4.34	7.04	9.75	12.45	15.15	17.86	20.56	23.27	25.97	28.68	31.38	
120	4.53	7.35	10.17	12.99	15.81	18.63	21.45	24.27	27.09	29.91	32.73	

HEIGHT (INCHES)

FREE AREA TABLE (SQUARE FEET)
RATING INCLUDES THE EFFECT OF A BIRDSCREEN

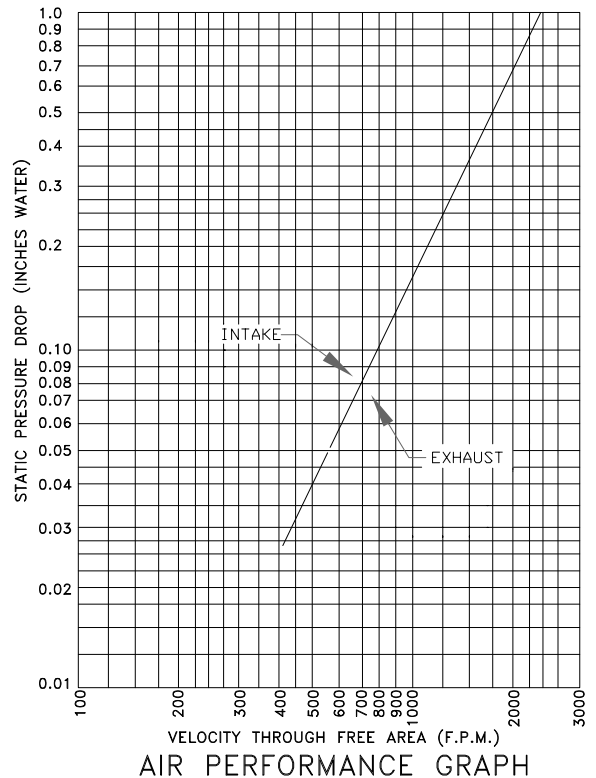
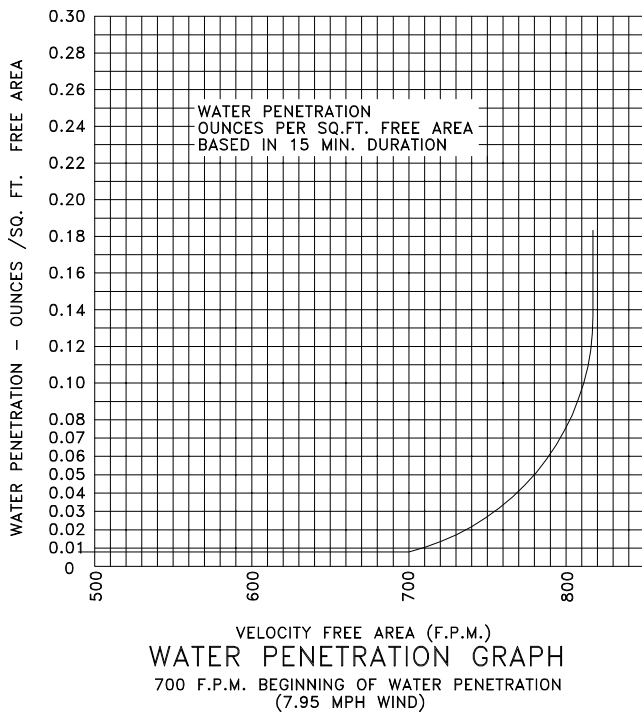

THE INFORMATION CONTAINED ON THIS DATA SHEET REMAINS THE PROPERTY OF WESTERN VENTILATION PRODUCTS LTD. AND IS PROTECTED BY COPYRIGHT. WESTVENT AIR PERFORMANCE RATINGS SHOWN ARE BASED ON TESTS MADE BY TECHNICIANS IN OUR TEST LABORATORY.